

◆ Specifications

GENERAL SPECIFICATIONS		
Power	DC12V (AC adapter), DC7.4V (Battery)	
Power consumption	Approx. 10 W (with VF in REC mode, default setting)	
Dimensions	177.5 mm (W) x 197 mm (H) x 415.5 mm (D)	
Weight	approx. 2.4 kg (including battery)	
Operation temperature	0°C to 40°C (32°F to 104°F)	
Storage temperature	-20°C to 50°C (14°F to 122°F)	
Operating humidity	30% to 80%	
Storage humidity	under 85%	
CAMERA		
Image sensor	1/3" CMOS 2.5M pixels	
Synchronizing	Internal synchronization	
Stabilizer	Optical image stabilizer	
Lens	F1.6 (wide) to F3.0 (Tele) f=4.1mm to 94.3mm (f=29 mm to 667mm (35mm equivalent))	
Filter diameter	72mm	
Shutter speed	1/6 ~ 1/10000, EEI	
Gain	(-6, -3: Extended mode only), 0, 3, 6, 9, 12, 15, 18, 21, 24 dB, Lolux (30, 36 dB), AGC	
ND filter	none, 1/4, 1/16, 1/64	
LCD display	3.5-inch 920 k pixels, 16:9	
Viewfinder	0.45-inch 1.22 M pixel, 16:9	
VIDEO/AUDIO RECORDING		
Recording media	2x SDHC/SDXC memory card (HD: Class 6/10 AVCHD/SD/Video: Class4)	
Video recording	Video codec	MPEG-4 AVC/H.264 (HD/SD), MPEG-2 Long GOP VBR (HD) MPEG-2 Long GOP CBR (HD), AVCHD (HD/SD)
	File format	MOV, MP4, MTS (AVCHD)
	HD (MPEG-2 Long GOP VBR)	NTSC setting: HQ mode: 1920 x 1080/59.94i, 29.97p, 23.98p, 1440 x 1080/59.94i 1280 x 720/59.94p, 29.97p, 23.98p (Max 35Mbps)
		PAL setting: HQ mode: 1920 x 1080/50i, 25p, 1440x1080/50i 1280 x 720/50i, 25p (Max 35Mbps)
	HD (MPEG-2 Long GOP CBR)	NTSC setting: SP mode: 1440x1080/59.94i, 1280x720/59.94p (18.3Mbps) PAL setting: SP mode: 1440x1080/50i, 1280x720/50p (18.3Mbps)
		NTSC setting: XHQ mode: 1920x1080/59.94p, 59.94i, 29.97p, 23.98p (Max 50Mbps) 1920x1080/59.94i, 29.97p, 23.98p (Max 35Mbps)
HD (H.264)	PAL setting: XHQ mode: 1920 x 1080/50p, 50i, 25p (Max 50Mbps) 1920 x 1080/50i, 25p (Max 35Mbps)	
	NTSC setting: Progressive mode (Max 28Mbps): 1920 x 1080/59.94p HQ mode (Max 24Mbps): 1920 x 1080/59.94i, SP mode (Max 18Mbps): 1920 x 1080/59.94i LP mode (9Mbps): 1440 x 1080/59.94i, EP mode (5Mbps): 1440 x 1080/59.94i	
AVCHD	PAL setting: Progressive mode (Max 28Mbps): 1920 x 1080/50p HQ mode (Max 24Mbps): 1920 x 1080/50i, SP mode (Max 18Mbps): 1920 x 1080/50i LP mode (9Mbps): 1440 x 1080/50i, EP mode (5Mbps): 1440 x 1080/50i	
	NTSC setting: 720 x 480/59.94i (GY-HM620U) PAL setting: 720 x 576/50i (GY-HM620E)	
SD (H.264)	NTSC setting: 720 x 480/59.94i (GY-HM620U) PAL setting: 720 x 576/50i (GY-HM620E)	
Audio recording	LPCM 2ch, 48kHz/16-bit (MOV/MP4), Dolby Digital, 2ch (AVCHD)	
INTERFACE		
Video output	AV output (ø3.5mm mini jack x1)	
	SDI output (BNC x1)	
	HDMI output x1	
Audio input	XLR x2 (MIC,+48V/LINE), ø3.5mm mini jack x1	
Audio output	AV output (ø3.5mm mini jack x1)	
Headphone	ø3.5mm mini jack x1	
Remote	ø2.5mm mini jack x1	
Time code link input/output	RCA x1	
USB	DEVICE x1 (Mass storage)	
PROVIDED ACCESSORIES		
Battery (SSL-JVC50) x1, AC Adapter x1		

◆ SDHC Class 4/6/10, SDXC recording time (approx.)

	MOV/MP4			MTS						MOV		
	MPEG-2/HD			AVCHD						H.264/HD		
	HQ	SP	720p	HQ Progressive	HQ	SP	LP	EP	XHQ	UHQ	SD	
	720p/1080i	1080i	720p	1080p	1080i						1080p/i	480i
4GB	12m	17m	22m	16m	19m	25m	46m	1h 22m	9m	12m	47m	
8GB	25m	35m	45m	33m	38m	50m	1h 35m	2h 48m	18m	25m	1h 35m	
16GB	50m	1h 10m	1h 30m	1h 7m	1h 18m	1h 40m	3h 10m	5h 36m	36m	50m	3h 10m	
32GB	1h 40m	2h 20m	3h	2h 15m	2h 36m	3h 20m	6h 20m	11h 12m	1h 12m	1h 40m	6h 20m	
64GB	3h 20m	4h 40m	6h	4h 30m	5h 12m	6h 40m	12h 40m	22h 24m	2h 25m	3h 20m	12h 40m	
128GB	6h 40m	9h 20m	12h	9h	10h 32m	13h 20m	25h 20m	44h 48m	4h 50m	6h 40m	25h 20m	

Notes: ● Recording times are estimate. ● Recommended SDHC/SDXC memory card brands: Panasonic, Toshiba, and SanDisk
● SDHC Class 10 enabled only in XHQ mode; SDHC Class 4 enabled in AVCHD mode.

◆ Dimensions

Unit: inches (mm)

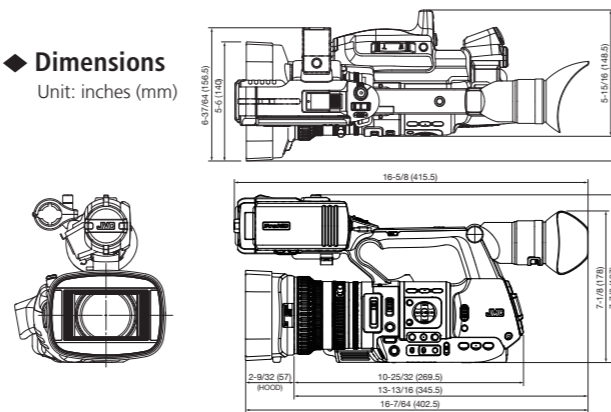

Apple, Apple logo, Macintosh, QuickTime, and Final Cut Pro are trademarks of Apple Inc. registered in the United States and other countries. "AVCHD Progressive/AVCHD" and the "AVCHD Progressive/AVCHD" logo are trademarks of Panasonic Corporation and Sony Corporation. Dolby is a registered trademark of Dolby Laboratories. The SD, SDHC and SDXC logos are trademarks of the SD Card Association. HDMI, the HDMI Logo, and High-Definition Multimedia Interface are trademarks or registered trademarks of HDMI Licensing LLC in the United States and other countries. Product and company names mentioned here are trademarks or registered trademarks of their respective owners. All screen pictures in this brochure are simulated.

Simulated pictures.
The values for weight and dimensions are approximate.
E.&O.E. Design and specifications subject to change without notice.

JVC

HD/SD Memory Card Camcorder

GY-HM620



Supreme Handheld Mobile News Camera



JVCKENWOOD

DISTRIBUTED BY

ProHD

HDMI HIGH-DEFINITION MULTIMEDIA INTERFACE

SD CLASS 10

SD CLASS 6

SD CLASS 4

SDXC

AVCHD Progressive

MOV QuickTime MP4

Shown with optional microphone.

The Camcorder Still Evolving – Enhanced Operability to Make the Most of Any Moment

The GY-HM620 is an advanced handheld ProHD camera that delivers unsurpassed imagery and other features for news, sports, and independent production. The new 620 has upgraded CMOS devices for greater sensitivity and a brighter LCD display for outdoor daylight viewing. Versatile and extremely easy to use, there's no better camera for fast-paced HD field production.



Newly developed 1/3-inch 3CMOS Sensor (1920 x 1080) boasts Sensitivity of F12/F13 (60/50Hz)

At the heart of the GY-HM620 are three, newly developed 1/3-inch CMOS sensors with 2.5M pixels, each capable of capturing full HD 1920 x 1080 resolution images. Featuring 12-bit processing, an excellent sensitivity of F12 (60Hz) /F13 (50Hz) at 2000 lux, and a remarkable signal-to-noise ratio, the devices provide superior precision and color reproduction with minimal aberration. For improved CMOS sensor performance, flash-band compensation is also supported.

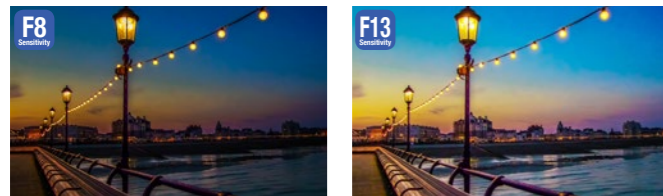

Compare the image brightness between sensitivity of F8 (left) of a conventional camera and F13 (50Hz) at 2000 lux on the GY-HM620.

Revolutionary FALCONBRID™ Image Processing Engine

FALCONBRID™ is JVC's high-speed processor for advanced video applications. Delivering tremendous processing power on a single chip, the on-board engine is capable of processing large amounts of video data at exceptional speeds. The combination of FALCONBRID™ engine, 2D DNR processing & compensation circuitry, and wide dynamic range achieve superior image quality.



FALCONBRID™

23x Fujinon Auto Focus Zoom Lens with Manual Functions

The GY-HM620 is equipped with the Fujinon wide angle 23x optical zoom lens to offer sufficient magnification for shooting. Delivering superior low-light performance and ensuring brightness at the tele end, the lens offers F1.6-3.0, a focal range of 29mm-667mm

(35mm equivalent) and includes servo zoom, manual focus, and iris rings, along with a four-position (clear, 1/4, 1/16 and 1/64) ND filter. Other features include an optical image stabilizer and chromatic aberration correction.



Focus, zoom and iris rings are isolated and ergonomically aligned with buttons offering intuitive, stress-free operations.

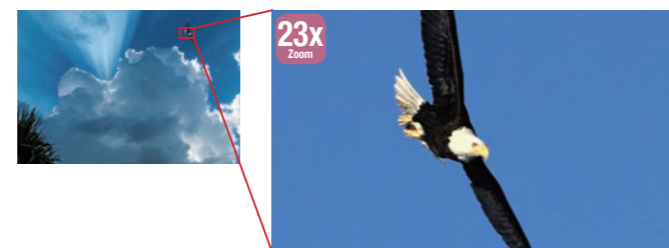

23x zoom lens, sufficient magnification for shooting, at Wide end (left) on to Tele end (right).

Upgraded High-resolution 920K Pixels 3.5-inch LCD Display with Focus Assist and various GUI

The high-resolution 920K pixels 3.5-inch LCD monitor provides a wide aspect ratio of 16:9 with a wide array of monitoring and setup indications. Since the LCD is top-mounted, not only is it ideal for shooting at various angles but also provides ample distance from the cameraman's eyes to the LCD to achieve better visibility in handheld camera applications. It also features a Focus Assist function that highlights the edges of objects shown in the viewfinder in color (red, green or blue) to help the cameraman stay focused on the action.

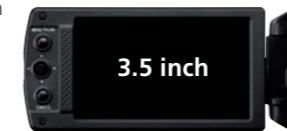

When the Focus Assist function is set to ON, objects that are in focus appear with colored edges (selectable from red, green or blue) as seen here.

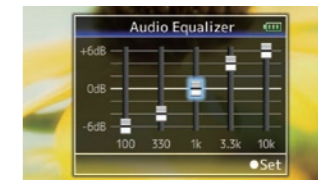

Audio equalizer

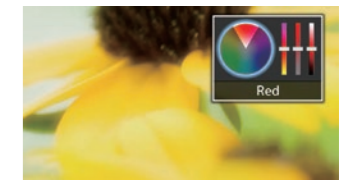

Color matrix adjustment

Dual SDHC/SDXC Card Slots for Maximum Versatility

Dual SDHC/SDXC card slots make the GY-HM620 a truly versatile camcorder, offering such benefits as series recording, dual recording, and backup recording modes with reliable and cost-effective media.

- **Series (relay) recording mode:** Continuous recording card by card.
- **Dual (simultaneous) recording mode:** Recording to 2 cards at same format for backup or multi-purpose.
- **Backup recording mode:** While the Rec trigger is used to REC and STOP recording on one card, the other card can act as a continuous backup that overrides the pause function.* This is a unique mode highly demanded by theatrical and bridal camera crew.

*During simultaneous backup recording in HD mode, the duplicate file records in the same file format and bit rate as the original.

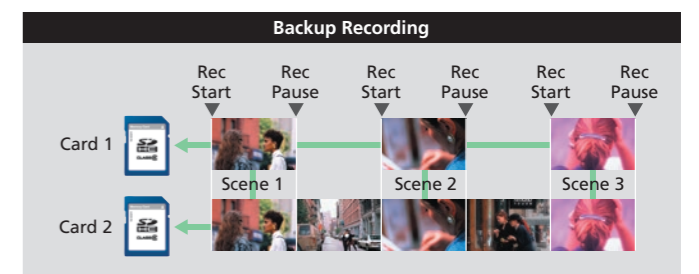

Various Codecs and File Formats including the Original H.264 XHQ (50Mbps) mode

FALCONBRID™ engine is capable of supporting major file formats such as .MOV with Apple Final Cut Pro, .MP4 of XDCAM EX™ cameras, and .MTS for AVCHD compatibility, as well as high-definition images in MPEG-2 35Mbps (HQ) and AVCHD 28Mbps (Progressive) format.

Furthermore, the processor also supports H.264 video format in 50Mbps extreme high quality (XHQ) mode for virtually no block noise and to capture high-speed moving subjects.

Video format	MPEG-2			AVCHD				H.264			
	HQ (35Mbps)	SP (25Mbps)	SP (19Mbps)	Progressive (28Mbps)	HQ (24Mbps)	SP (18Mbps)	LP (9Mbps)	EP (5Mbps)	XHQ (50Mbps)	UHQ (35Mbps)	SD (8Mbps)
Mode (Bit rate)											
File format	MOV/MP4			MTS				MOV			
Audio format	Linear PCM 2ch			AC3 2ch				Linear PCM 2ch			
HD	1920 x 1080	60i/50i/30p/25p/24p		60p/50p	60i/50i	60i/50i			60p/60i/50p/50i/30p/25p/24p	60i/50i/30p/25p/24p	
	1440 x 1080	60i/50i	60i/50i				60i/50i	60i/50i			
	1280 x 720	60p/50p/30p/25p/24p*1		60p/50p							
SD	720 x 480									60i/50i*3	

*1: Only with MOV/M4 file formats *2: U only *3: E only

Just for Professional Utility – Cutting-edge Connectivity including SDI (HD/SD) Out

Equipped with leading edge connections, the GY-HM620 offers versatility while meeting the needs of professional applications. For easy monitoring of footage, you can monitor from the digital SDI and HDMI outputs simultaneously, easily switching between output in HD or SD.

- SDI (HD/SD) out
- HDMI (HD/SD) out (60p support)
- TC Sync in/out
- AV out
- USB (Device x1)
- XLR 3-pin x2 (MIC, +48V <phantom power>, LINE)
- Aux in for Wireless Receiver
- ø2.5mm Remote Control
- ø3.5mm Stereo Headphone out



Optional Accessories



SSL-JVC50
Standard Li-ion Battery (IDX)
DC7.4V, 4900mAh, 37Wh



SSL-JVC75
Long-life Li-ion Battery with D-TAP Connector (IDX)
DC7.4V, 7350mAh, 55Wh



LC-2J
7.4V 2-ch Simultaneous Charger (IDX)